

Fazid 6/24



### SUBMITTAL TRANSMITTAL

### RICHEY FUEL TANK REPLACEMENT

June 24, 2011

To: M3 ENGINEERING AND TECHNOLOGY  
2051 W. Sunset Road, Suite 101  
Tucson, Arizona 85704

From: Miller O'Hern Construction, LLC  
2200 S. Avenida Los Reyes  
Tucson, Arizona 85748

MILLER O'HERN CONSTRUCTION has reviewed this submittal and believes it to be in substantial compliance with the contract documents.

By: [Signature]

Date: 6.24.11

Subcontractor: A and H Contracting Services  
Manufacturer: Various  
Supplier:

Miller O'Hern Construction, LLC 520-395-9479

Specification Section: 2254 Fuel Piping, Valves, Leak Detectors

Submittal Purpose:  For Approval  
 For Information Only

Submittal Type  Product Data  Shop Drawing  Sample  
Number of Copies

Remarks:

Signature [Signature]

15 pages

MILLER O'HERN CONSTRUCTION has reviewed this submittal and believes it to be in substantial compliance with the contract documents.

2554 2.3A

By: DMSO

Date: 6.24.11

Miller O'Hern Construction, LLC 520-395-9479



ANVIL INTERNATIONAL, INC.  
Dino L. Herring, Cashier

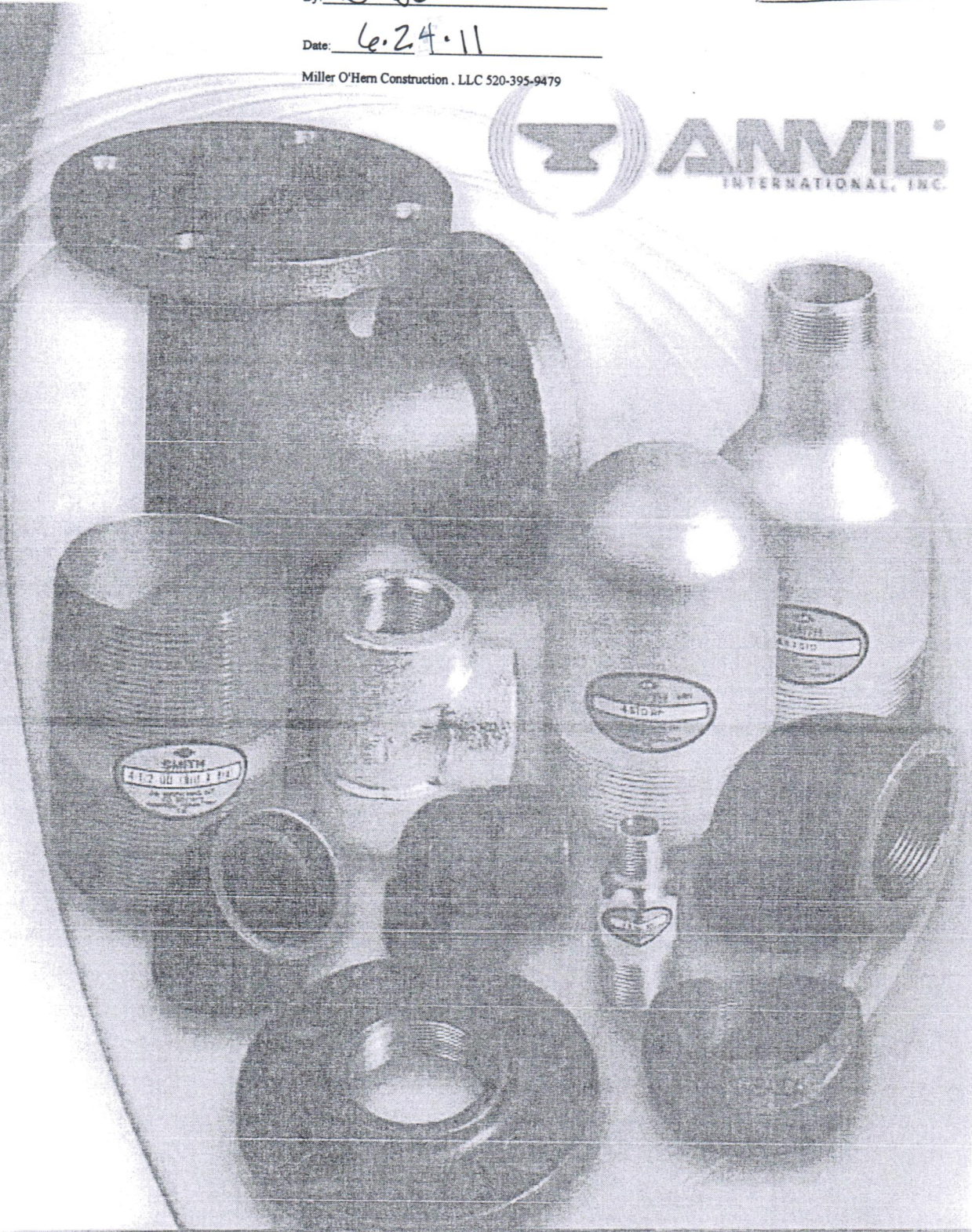

**PIPE FITTINGS** Steel • Cast Iron • Malleable

[www.anvilintl.com](http://www.anvilintl.com)

PF-10.02

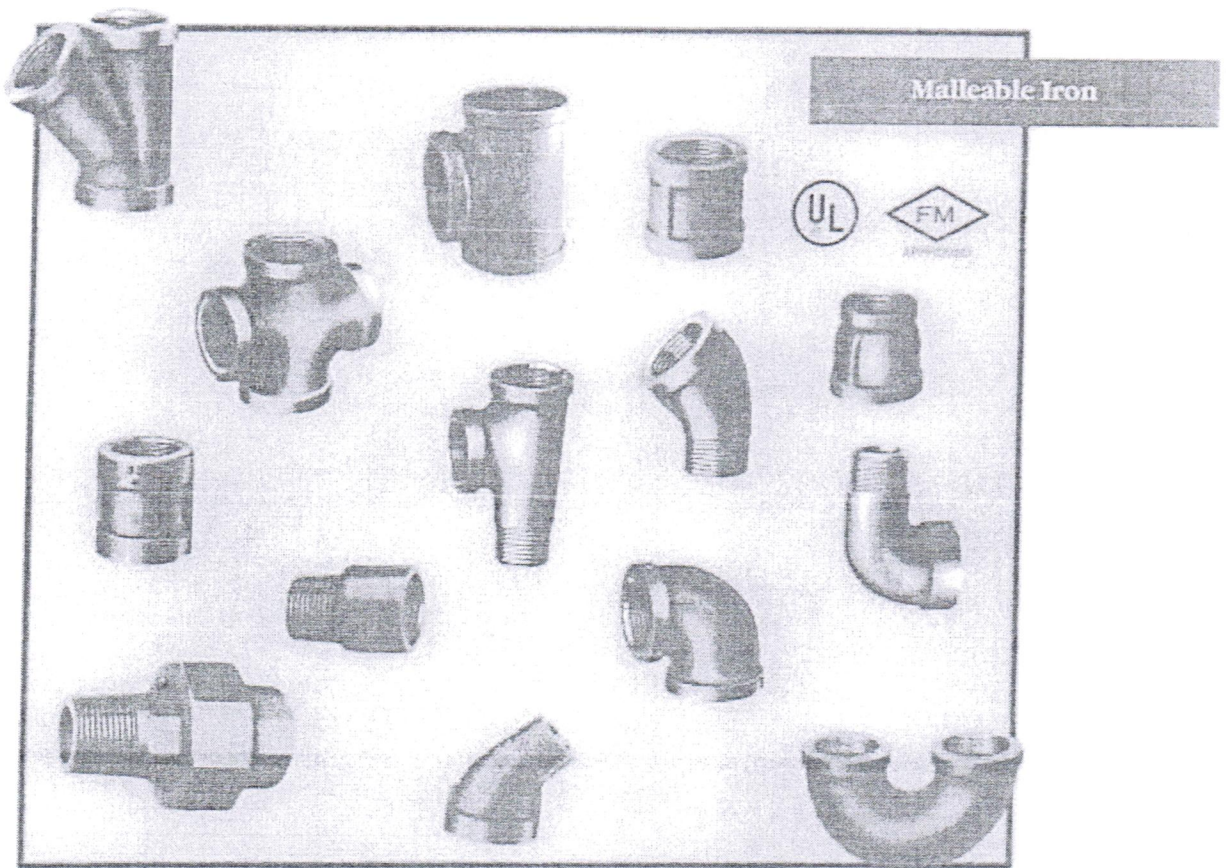

**Malleable Iron Threaded Pipe With Unions  
Pressure - Temperature Ratings**

Temperature		Pressure					
		Class 150		Class 250		Class 300	
(°F)	(°C)	psi	bar	psi	bar	psi	bar
-20° to 150°	-28.9° to 65.6°	300	20.7	500	34.5	600	41.4
200°	93.3	265	18.3	455	31.4	550	37.9
250°	121.1	225	15.5	405	27.9	505	34.8
300°	148.9	185	12.9	360	24.8	460	31.7
350°	176.7	150	10.3	315	21.7	415	28.6
400°	204.4	110	7.6	270	18.6	370	25.5
450°	232.2	75	5.2	225	15.5	325	22.4
500°	260.0	-	-	180	12.4	280	19.3
550°	287.8	-	-	130	9.0	230	15.9

Note: Unions with Copper or Copper Alloy seats are not intended for use where temperature exceeds 450°F

**Malleable Iron Threaded Fittings  
Pressure - Temperature Ratings**

Temperature		Pressure							
		Class 150		Class 300					
				Sizes 1/4" - 1" (6 - 25 mm)		Sizes 1" - 2" (32 - 51 mm)		Sizes 2 1/2" - 3" (64 - 76 mm)	
(°F)	(°C)	psi	bar	psi	bar	psi	bar	psi	bar
-20° to 150°	-28.9° to 65.6°	300	20.7	2,000	137.9	1,500	103.4	1,000	68.9
200°	93.3	265	18.3	1,785	123.1	1,350	93.1	910	62.7
250°	121.1	225	15.5	1,575	108.6	1,200	82.7	825	56.9
300°	148.9	185	12.9	1,380	93.8	1,050	72.4	735	50.7
350°	176.7	150	10.3	1,150	79.3	900	62.1	650	44.8
400°	204.4	-	-	935	64.5	750	51.7	550	38.6
450°	232.2	-	-	725	50.0	600	41.4	475	32.8
500°	260.0	-	-	510	35.2	450	31.0	385	26.5
550°	287.8	-	-	300	20.7	300	20.7	300	20.7

Anvil Class 150 (standard Weight) Malleable Iron Fittings conform to ASME B16.3 and Unions conform to ASME B16.39.

Anvil standard weight banded pattern fittings in this catalog, sizes 1/2" NPS to 6" NPS (6 to 150 DN) inclusive, are included in the "List

of Inspected Fire Protection Equipment and Materials" issued by the Underwriters' Laboratories, Inc.

ALL ELBOWS & TEES 1/2" (10 DN) and LARGER ARE 100% GAS TESTED AT A MINIMUM OF 100 PSI (6.9 bar)

# SPF MALLEABLE IRON FITTINGS

## Class 150 (Standard)

### STANDARDS & SPECIFICATIONS

#### Import Malleable Iron Screwed Fittings (Class 150)

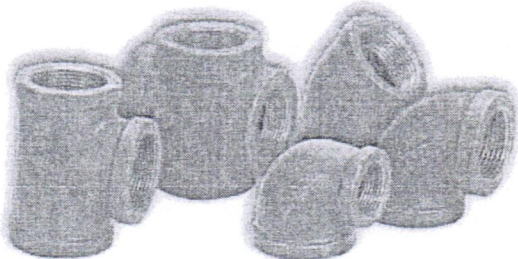
Dimensional:	Fittings:	ASME B16.3	
	Unions:	ASME B 16.39 ✓	
	Bushings/Plugs:	ASME B 16.14	
Material:	ASTM A-197		
Galvanizing:	ASTM A-153 ✓	(Hot Dip Galvanizing)	
Threading:*	ASME B 1.20.1		
Pressure Rating:	Fittings:	ASME B 16.3	
	Unions:	ASME B 16.39	
	Bushings/Plugs:	ASME B 16.14	
Pressure Testing:	All malleable iron fittings are tested for through wall porosity using an air under water process.		
Agency Approvals:	All malleable iron fittings and unions are UL Listed and FM Approved.		

\*British Standard threading per BS 21 available upon request.

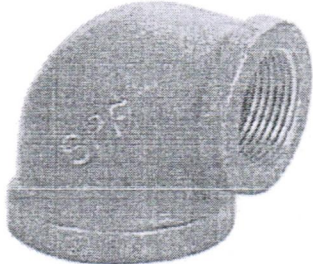
90° REDUCING ELBOW	Size	A	B	Weight
	in	in	in	lbs
	1/2 x 1/2	0.74	0.76	0.08
	3/8 x 1/2	0.81	0.85	0.11
	3/8 x 1/4	0.88	0.90	0.13
	1/2 x 1/4	0.97	0.98	0.16
	1/2 x 3/8	1.04	1.03	0.19
	3/4 x 3/8	1.12	1.13	0.26
	3/4 x 1/2	1.20	1.22	0.29
	1 x 3/8	1.26	1.36	0.42
	1 x 1/4	1.37	1.45	0.47
	1 1/4 x 1/2	1.34	1.53	0.54
	1 1/4 x 3/4	1.45	1.62	0.62
	1 1/4 x 1	1.58	1.67	0.73
	1 1/2 x 3/4	1.52	1.75	0.74
	1 1/2 x 1	1.65	1.80	0.88
	1 1/2 x 1 1/4	1.82	1.88	1.03
	2 x 3/4	1.60	1.97	1.04
	2 x 1	1.73	2.02	1.28
	2 x 1 1/4	1.90	2.10	1.36
	2 x 1 1/2	2.02	2.16	1.51
	2 1/2 x 1 1/2	2.16	2.51	2.20
	2 1/2 x 2	2.39	2.60	2.55
	3 x 2	2.52	2.89	3.35
	3 x 2 1/2	2.83	2.99	4.12
	4 x 3	3.30	3.60	6.65

# SPF MALLEABLE IRON FITTINGS

## Class 150 (Standard)

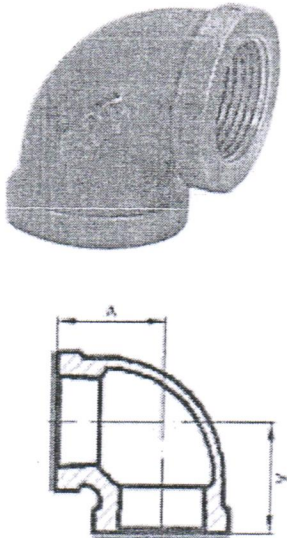
90° ELBOW	Size	A	Weight
	in	in	lbs
	1/8	0.69	0.06
	1/4	0.81	0.10
	3/8	0.95	0.15
	1/2	1.12	0.22
	3/4	1.31	0.36
	1	1.50	0.57
	1 1/4	1.75	0.87
	1 1/2	1.94	1.16
	2	2.25	1.81
	2 1/2	2.70	3.23
	3	3.08	4.82
	4	3.79	8.41
	6	5.13	19.96

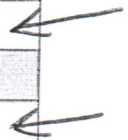

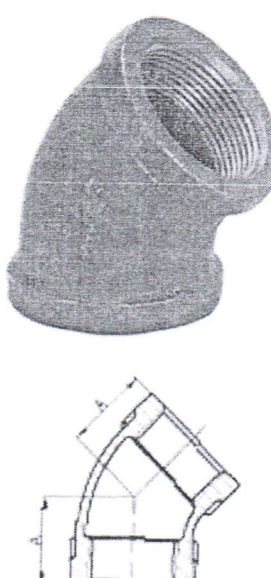
45° ELBOW	Size	A	Weight
	in	in	lbs
	1/8	0.63	0.06
	1/4	0.73	0.11
	3/8	0.80	0.14
	1/2	0.88	0.20
	3/4	0.98	0.32
	1	1.12	0.50
	1 1/4	1.29	0.76
	1 1/2	1.43	1.00
	2	1.68	1.61
	2 1/2	1.95	2.77
	3	2.17	4.03
	4	2.61	6.92
	6	3.46	16.31

# SPF MALLEABLE IRON FITTINGS

## Class 150 (Standard)

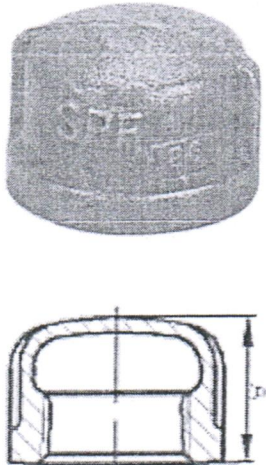
CAP	Size	A	Weight
	in	in	lbs
	1/8	0.53	0.03
	1/4	0.63	0.05
	3/8	0.74	0.07
	1/2	0.87	0.11
	3/4	0.97	0.18
	1	1.16	0.30
	1 1/4	1.28	0.44
	1 1/2	1.33	0.55
	2	1.45	0.85
	2 1/2	1.70	1.49
	3	1.80	2.20
	3 1/2	1.90	3.02
	4	2.08	3.79
6	2.55	8.77	

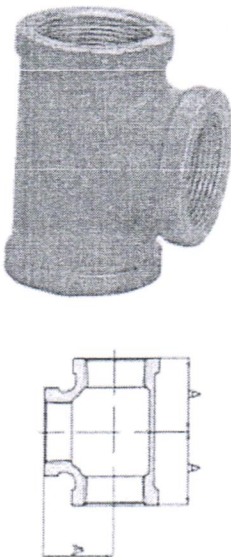
TEE	Size	A	Weight
	in	in	lbs
	1/8	0.69	0.09
	1/4	0.81	0.14
	3/8	0.95	0.21
	1/2	1.12	0.31
	3/4	1.31	0.50
	1	1.50	0.79
	1 1/4	1.75	1.19
	1 1/2	1.94	1.57
	2	2.25	2.43
	2 1/2	2.70	4.33
	3	3.08	6.37
	4	3.79	11.03

# SPF MALLEABLE IRON FITTINGS

## Class 150 (Standard)

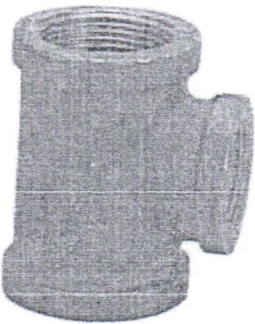
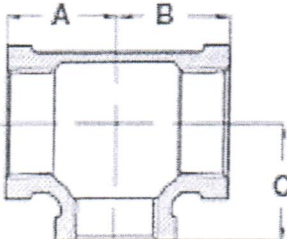
REDUCING TEE	Size		A	B	C	Weight	
	in	in	in	in	in	lbs	
 	1 1/2	1/2	1 1/2	1.94	1.66	1.94	1.24
		3/4	3/4	1.50	1.26	1.69	0.86
			1 1/2	1.94	1.75	1.94	1.29
		1	1	1.65	1.50	1.80	1.08
			1 1/4	1.82	1.67	1.88	1.23
			1 1/2	1.94	1.80	1.94	1.35
		1 1/4	3/4	1.52	1.45	1.75	1.04
			1	1.65	1.58	1.80	1.17
			1 1/4	1.82	1.75	1.88	1.32
		1 1/2	1 1/2	1.94	1.88	1.94	1.45
			2	2.16	2.16	2.02	1.89
			2 1/2	2.60	2.60	2.39	3.15
	3		2.29	2.29	2.80	4.45	
	2	1/2	1.41	1.41	1.66	1.04	
		3/4	1.52	1.52	1.75	1.14	
		1	1.65	1.65	1.80	1.27	
		1 1/4	1.82	1.82	1.88	1.43	
		1 1/2	1.94	1.94	1.94	1.45	
		2	2.16	2.16	2.02	1.89	
	2 1/2	1/2	2	2.25	1.88	2.25	1.89
		3/4	2	2.25	1.97	2.25	1.93
		1	2	2.25	2.02	2.25	2.00
		1 1/4	1 1/4	1.90	1.75	2.10	1.64
		1 1/2	1 1/2	2.02	1.88	2.16	1.80
		2	2	2.25	2.10	2.25	2.09
		2 1/2	2 1/2	2.60	2.60	2.39	3.15
		3	2.29	2.29	2.80	4.45	
	3	1	1.73	1.65	2.02	1.57	
		1 1/4	1.90	1.82	2.10	1.71	
		1 1/2	2.02	1.94	2.16	1.88	
		2	2.25	2.16	2.25	2.21	
	4	1/2	1.49	1.49	1.88	1.53	
		3/4	1.60	1.60	1.97	1.63	
		1	1.73	1.73	2.02	1.78	
		1 1/4	1.90	1.90	2.10	1.97	
		1 1/2	2.02	2.02	2.16	2.12	
4	2	2.39	2.39	2.60	3.65		
	2 1/2	2.83	2.83	2.99	5.69		
	3	3.30	3.30	3.60	9.25		

# ASTM A53

## Type E Grade B Pipe

### Scope

Covers black and hot-dipped galvanized electric-resistance welded Grade B pipe. Pipe is intended for mechanical and pressure applications and is acceptable for ordinary uses in steam, water, gas and air lines. Pipe is suitable for welding, threading, grooving.

### Manufacture

The weld seam shall be heat treated after welding to a minimum of 1000° F or be otherwise processed in such a manner that no untempered martensite remains.

### Hot-Dipped Galvanized

The average weight of zinc coating shall be not less than 1.8 oz. per sq. ft. of surface (inside and outside).

When galvanized pipe is bent or otherwise fabricated to a degree which causes zinc coating to stretch or compress beyond the limit of elasticity, some flaking of the coating may occur.

### Hydrostatic and Nondestructive Testing

Hydrostatic inspection test pressures for plain-end pipe are listed in Table X2.2 of the A53 specification. Test pressures shall be maintained for a minimum of five seconds.

Nondestructive testing of the weld seam is required on each length of ERW pipe NPS 2" and larger.

### Chemical Requirements

#### Composition, max. %

Carbon	Manganese	Phosphorus	Sulfur	
.30	1.20	.05	.045	
Copper	Nickel	Chromium	Molybdenum	Vanadium
.40	.40	.40	.15	.08

\*The combination of these five elements shall not exceed 1.00%.

### Tensile Requirements

Tensile Strength, min.	60,000 psi
Yield Strength, min.	35,000 psi
Elongation in 2"	Refer to A53 Table X4.1

Note: A transverse test is required on pipe NPS 8 and larger.

### Bending Test (Cold)

For NPS 2" and under

Degree of Bend	Diameter of Mandrel
90	12 x outside pipe diameter

### Flattening Test

As a test for quality of the weld for pipe 2" NPS and larger, position the weld at 0° to the direction of force and flatten until the OD is 2/3 of the original outside diameter. No cracks shall occur along the inside or outside surface of the weld.

### Frequency of Tests

Tensile tests are required on one length of pipe each lot of 500 lengths or fraction thereof for each size. Refer to A53 specification for frequency of flattening tests.

### End Finish

**Plain End:** NPS 2" and larger, STD and XS weights: ends beveled to angle of 30°, +5°, -0° with a root face of 1/16" ± 1/32"

**Threaded:** To ANSI Standard B 1.20.1

**Couplings:** To ASTM Standard A 865

### Dimensions and Weights

The dimensions and weights furnished under this specification are in agreement with the standardized dimensions and weights specified in ASME B 36.10.

### Permissible Variations in Wall Thickness

Minimum wall thickness at any point shall not be more than 12.5% under nominal wall thickness specified.

### Permissible Variations in Outside Diameter

Pipe NPS and larger shall not vary more than ± 1% from the standard specified.

Standard (Sch. 40) Black Plain End			
Nominal Size	OD Inches	Wall	Weight Lbs./Ft.
2"	2.375	.154	3.66
2 1/2"	2.875	.203	5.80
3"	3.500	.216	7.58
3 1/2"	4.000	.226	9.12
4"	4.500	.237	10.80
5"	5.563	.258	14.63
6"	6.625	.280	18.99
8"	8.625	.322	28.58
Extra Strong (Sch. 80) Black Plain End			
Nominal Size	OD Inches	Wall	Weight Lbs./Ft.
2"	2.375	.218	5.03
2 1/2"	2.875	.276	7.57
3"	3.500	.300	10.26
3 1/2"	4.000	.318	12.52
4"	4.500	.337	15.00

### Permissible Variations in Weight per Foot

Pipe shall not vary more than ± 10% from the standard specified.

### Product Marking

Each length of pipe is continuously stenciled to show the manufacturer, the grade of pipe (ASTM A53), the kind of pipe (E for electric-resistance welded, B for Grade B), the size, XS for extra strong, and length.

# Apollo® 82-100 Series

## Bronze 3-Piece Full Port Ball Valve

Threated, 600 psig WOG, Cold Non-Shock. 150 psig Saturated Steam.  
Vacuum Service to 29 inches Hg.

Federal Specification: WW-V-35C, Type: II, Composition: BZ, Style: 1.  
MSS SP-110; Ball Valve Threaded, Socket-Welding, Solder Joint, Grooved and Flared Ends.

### FEATURES

- Full port configuration
- RPTFE seats and seals
- In-line repairable
- Blow-out-proof stem design
- Adjustable packing gland

### STANDARD MATERIAL LIST

1. Lever and grip	Steel, zinc plated w/vinyl	10. Body bolt	Steel, zinc plated
2. Stem packing	RPTFE	11. Hex nut	Steel, zinc plated
3. Stem bearing	RPTFE	12. Body	B584-C84400
4. Ball	B16, chrome plated (except 3" & 4")		
5. Seat (2)	RPTFE		
6. End cap (2)	B16 (1/4" to 3/8") B584-C84400 (1/2" to 4")		
7. Gland nut	B16		
8. Stem	B16 (except 3" & 4")		
9. Lever nut	Steel, zinc plated		

### VARIATIONS AVAILABLE:

- 82-140 Series (316 SS Ball & Stem)
- 82-150 Series (Original Balancing Stop)

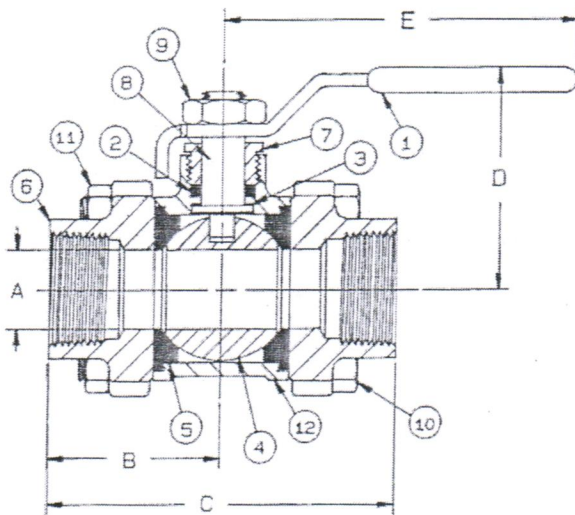

BRONZE 3-PIECE FULL PORT BALL VALVE

NUMBER	SIZE	A	B	C	D	E	Wt.
82-101-01	1/4"	.43	1.28	2.56	1.81	3.87	1.02
82-102-01	3/8"	.50	1.28	2.56	1.81	3.87	1.04
82-103-01	1/2"	.62	1.40	2.81	1.93	4.87	1.55
82-104-01	3/4"	.81	1.71	3.43	2.18	4.87	2.27
82-105-01	1"	1.00	1.93	3.87	2.62	5.50	3.28
82-106-01	1-1/4"	1.25	2.37	4.75	2.87	5.50	5.62
82-107-01	1-1/2"	1.50	2.62	5.25	3.37	8.00	8.07
82-108-01	2"	2.00	3.01	6.03	3.68	8.00	14.42
82-109-01	2-1/2"	2.50	3.62	7.25	5.14	9.75	26.61
82-140-01	3"	3.00	4.00	8.00	6.77	18.00	42.24
62-14A-01	4"	4.00	5.50	11.00	8.26	18.00	88.40

### OPTIONS AVAILABLE:

(SUFFIX)	OPTION	SIZES
-02-	Static Grounded	1/4" to 4"
-03-	1-1/4" Stem Extension	1/4" to 2"
-04-	2-1/4" Stem Extension	1/4" to 2"
-05-	Plain Ball	1/4" to 4"
-07-	Tee Handle	1/4" to 2"
-08-	90° Reversed Stem	1/4" to 4"
-10-	SS Lever & Nut	1/4" to 4"
-14-	Vented Ball (see page J-2)	1/4" to 4"
-15-	Round Handle	1/4" to 2"
-16-	Vertical Chain Lever	1/2" to 2"
-18-	Plain Yellow Grip	1/4" to 2"
-19-	Lock Plate	1/4" to 4"
-20-	Slot Vented Ball	1/4" to 4"
-21-	UHMWPE Seats	1/4" to 4"
-23-	Tank Flange	2" ONLY
-24-	Graphite Stem Packing	1/4" to 4"
-27-	Latch Lock Lever	1/2" to 2"
-30-	CamLock Handle	1/4" to 1-1/4"
-32-	SS Tee Handle & Nut	1/4" to 2"
-35-	PTFE Trim	1/4" to 4"
-39-	SS Hi-Rise Locking Wheel Handle, SS Nut	1/4" to 1-1/4"
-40-	Cyl-Loc & Grounded	1/4" to 1/2"
-45-	Leas Lever & Nut	1/4" to 4"
-46-	Latch-Lock Lever - Lock in Closed Position Only	1/2" to 2"
-47-	SS Oval Latch-Lock Handle & Nut	1/4" to 3/4"
-48-	SS Oval Handle (No Latch) & Nut	1/4" to 2"
-49-	Assembled Dry	1/4" to 4"
-50-	2-1/4" CS Locking Stem Extension	1/4" to 2"
-56-	Multifill Seats & Graphite Packing	1/4" - 4"
-57-	Oxygen Cleaned	1/4" to 4"
-58-	Chain Lever - Horizontal	1/2" to 2"
-59-	SS External Trim - 3-pc. Valves	1/4" to 4"
-60-	Grounded Ball & Stem	1/4" to 4"
-63-	NPT x Solder/Socket Weld	3/8" to 4"
-P01-	BSPP (Parallel) Thread Connection	1/4" to 4"
-T01-	BSPT (Tapered) Thread Connection	1/4" to 4"

**For Pressure/Temperature Ratings,  
Refer to Page M-8, Graph No. 4**



**Advantages**

- Cylindrical float design eliminates interference with tank walls and cross braces.
- 100 psi working pressure rating.
- Flow rate 200 gpm at 20 psi.
- No minimum flow rate.
- Ships complete with upper nipple and tight fill adapter with crossbar to prevent open fills.
- Simply thread onto a 4" riser pipe to install. Length of upper tube determines shut-off point.
- CARB approved AGT 98-1.



**Materials**

- Valve body: aluminum 356-T6.
- Poppet: aluminum 356-T6.
- Shaft: stainless steel.
- Float: high density polyethylene.
- Nipple: epoxy coated black iron pipe.

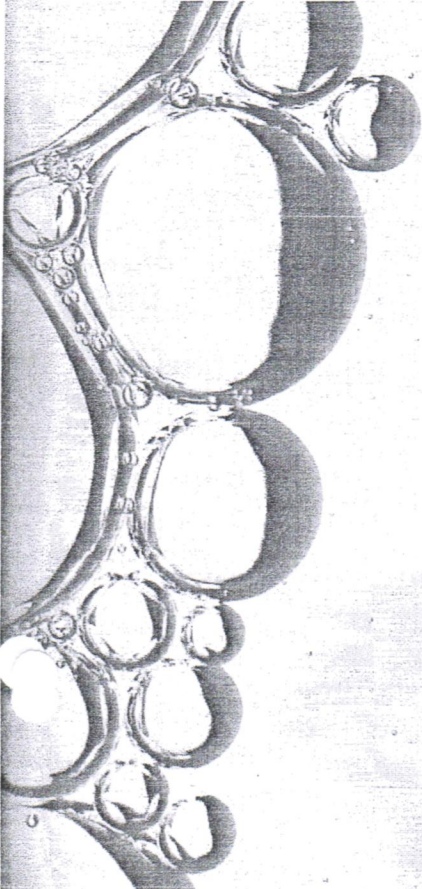

# 709 Warden® AST Overfill Prevention Valve

The EBW Warden® is designed to provide a positive shut-off during a pressurized fill delivery on an aboveground storage tank. It eliminates spills and overfills, avoiding costly cleanup expenses and ground contamination. The Warden® is fully adjustable to provide shut-off in various height and capacity aboveground tanks. It is designed to fit into a 4" fill riser, making installation on new and existing locations simple and quick. Designed with inverted floats for use in small or large rectangular tanks. Requires 4" minimum ullage.

Note: The Warden® is recommended for use with clean product only. Contaminated product may cause erratic operation or valve failure

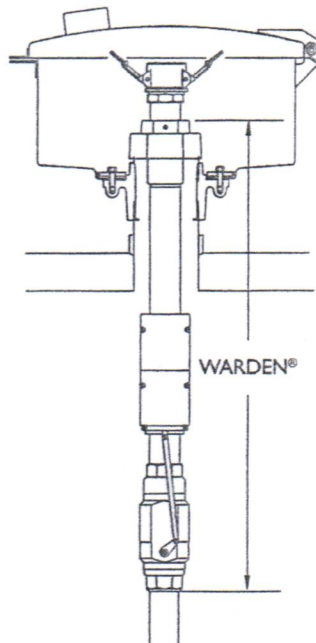
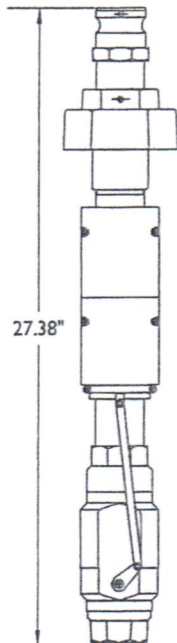

Model	Description	Weight		List
		Lbs.	Kg	
709-420-01	Warden®, 4" overfill with inverted floats	12.50	5.67	
774-212-20	2" dust cap	1.25	0.57	

2554 2.6A.3

# Submersible Turbine Pumps



Submersible Pumping Systems

## Mechanical Line Leak Detector

For use with 4" STPs, the MLD product line is precision built, with unique construction features that provide busy stations with maximum flow rates and long service life. The MLD is offered in three models to match your exact application, ensuring accurate, nuisance-free operation critical to profitable station operation.

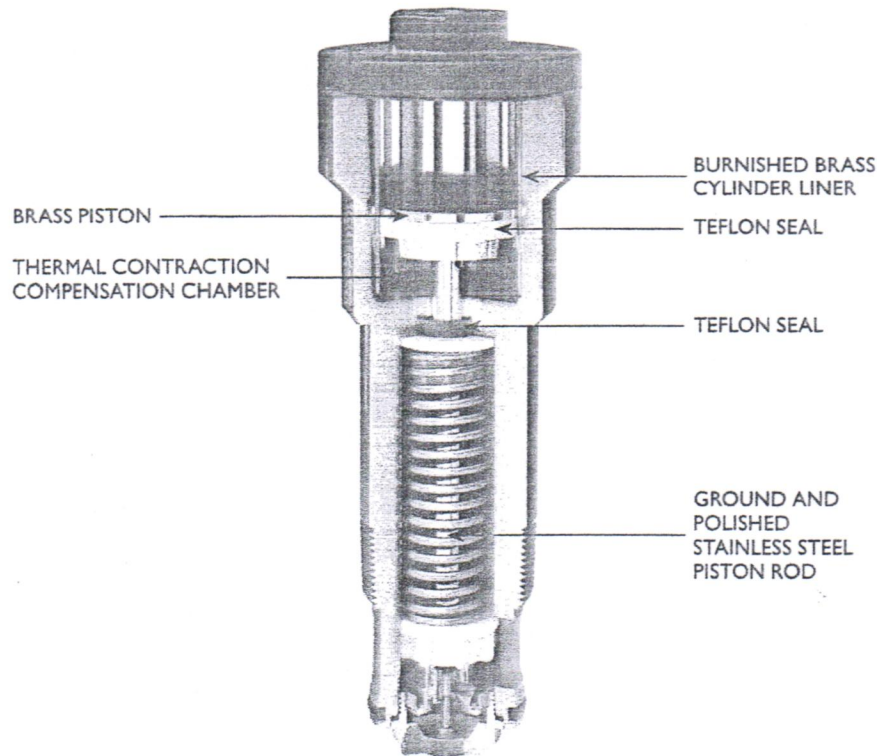

### Advantages

- All models are capable of detecting line leaks equivalent to 3 gph at 10 psi when installed properly with the appropriate fuels. All models will signal detection of leaks by restricting product delivery to less than 3 gpm and taking more than 4 seconds to open.
- All models require 2 to 3 seconds to make a line test when no line leaks exist and air is purged from piping between the discharge of the MLD and the dispenser solenoid.
- All models will remain in the "open" position during product delivery to manifold, with discharge pressures as low as 1 psi. All models will reset to "tripped" when line pressure delay is below 3 psi with pump off.
- All models will detect leaks up to 10 feet above the MLD installation point.



### Specifications:

- Three models: STP-MLD (blue) for gasoline, STP-MLD-D (tan) for diesel and STP-MLD-E (grey) for some expandable pipe applications.
- Solid brass piston has 1-5/8" of travel to move the leak detection poppet fully out of the flow, offering minimum flow restriction and maximum flow rates.
- Burnished brass cylinder liner and polished stainless steel piston rod ensure smooth operation and long life from the Teflon seal.
- Thermal compensation chamber of 5¼ cubic inches helps minimize thermal contraction nuisance tripping.

### Liquid Compatibility

- Max. liquid viscosity: 70 SSU at 60 °F (15 °C).
- STP-MLD and STP-MLD-E models are compatible with fuel mixtures containing up to 100% ethanol or methanol, and 20% MTBE, 20% ETBE or 17% TAME with gasoline, as well as diesel fuels, fuel oils, kerosene, Avgas and jet fuels.
- STP-MLD-D models are listed for diesel fuels or kerosene only.

### Approvals

- Third party certified to comply with US EPA requirements 280.41 (B) and 280.44 (A) for continuous monitoring of pressurized piping.
- Consult factory for other applicable approvals.

### Quality Certification

- Franklin Fueling Systems is an ISO 9001 Certified Manufacturer.

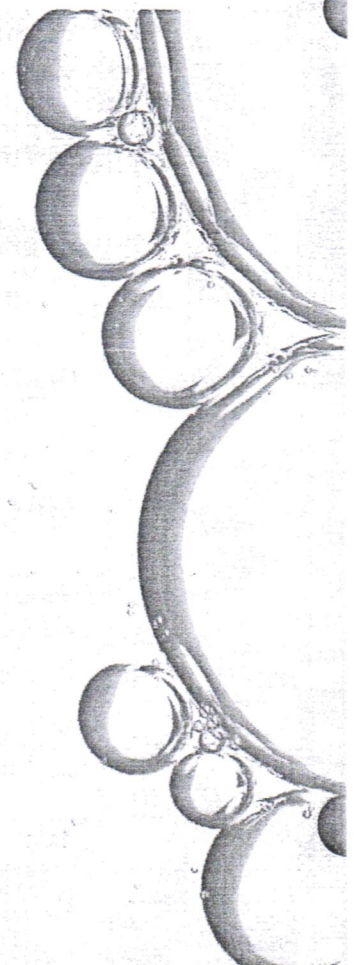

## Mechanical Line Leak Detector (for use with 4" STPs)\*

### Single Pack

Part Number	Description	List
400500901	STP-MLD for gasoline, blue	
400501901	STP-MLD-D for diesel or kerosene, tan	
400502901**	STP-MLD-E for expandable piping, grey	

### Three Pack

Part Number	Description	List
400500903	STP-MLD for gasoline	
400501903	STP-MLD-D for diesel or kerosene	
400502903**	STP-MLD-E for expandable piping	
400503903	COMBO, contains two STP-MLDs and one STP-MLD-D	

Notes: 1. MLD and MLD-E models are compatible with fuel mixtures containing up to 100% ethanol or methanol with gasoline, diesel fuels, and 20% MTBE, 20% ETBE or 17% TAME with gasoline.

2. MLD-D models are listed for compatibility with diesel fuels and kerosene applications only.

3. All above models will only mount in the 2" NPT leak detector port of a 4" submersible turbine, including competitive models, or in a leak detector adapter tee (sold separately below).

\*Designed for limited flexible piping systems with low bulk modulus, consult factory before ordering.

\*\*Refer to STP-MLD installation manual for complete compatibility specifications.

## MLD Repair Parts and Accessories

Part Number	Description	List
400440101	MLD vent tube	
400449901	MLD hardware pack, fittings and documentation	
400518001	Leak detector adapter tee	

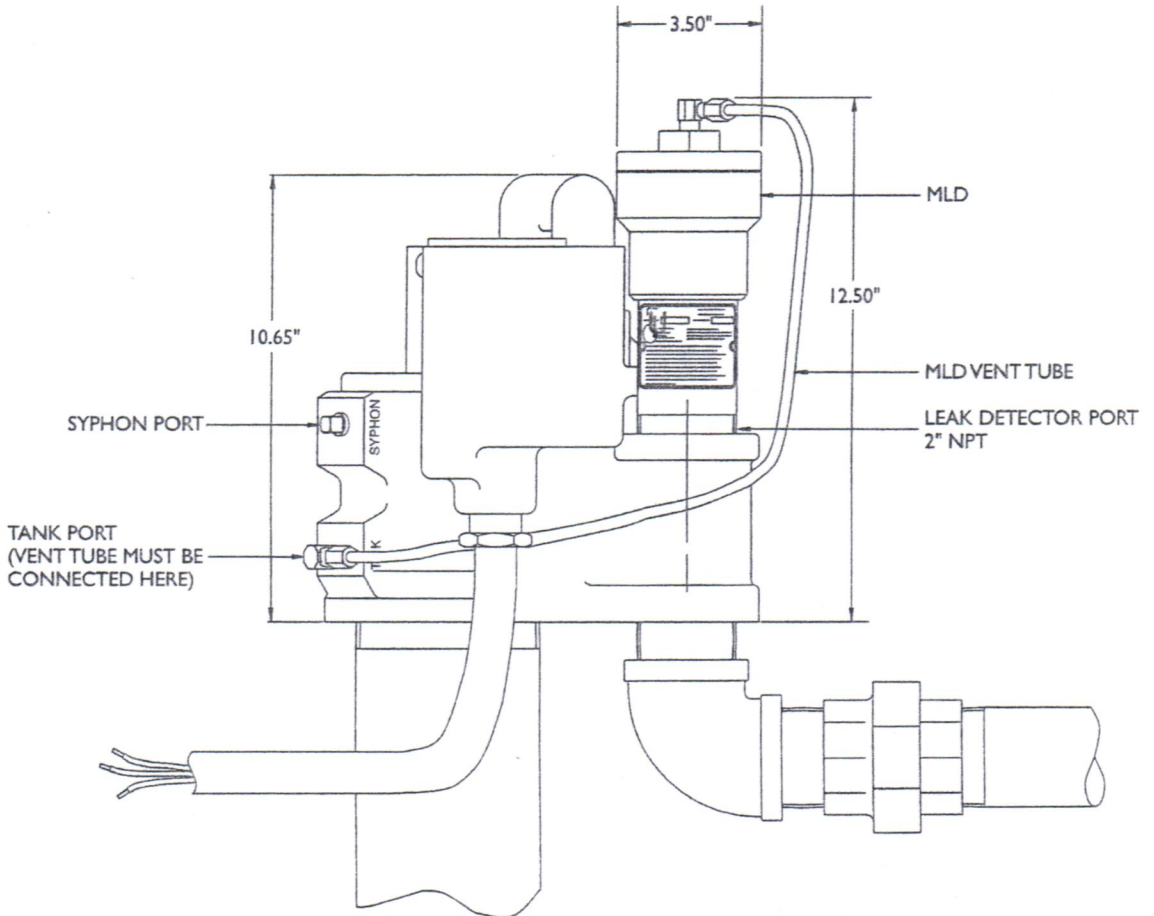

2554 2.7.10  
15192 2.10.0

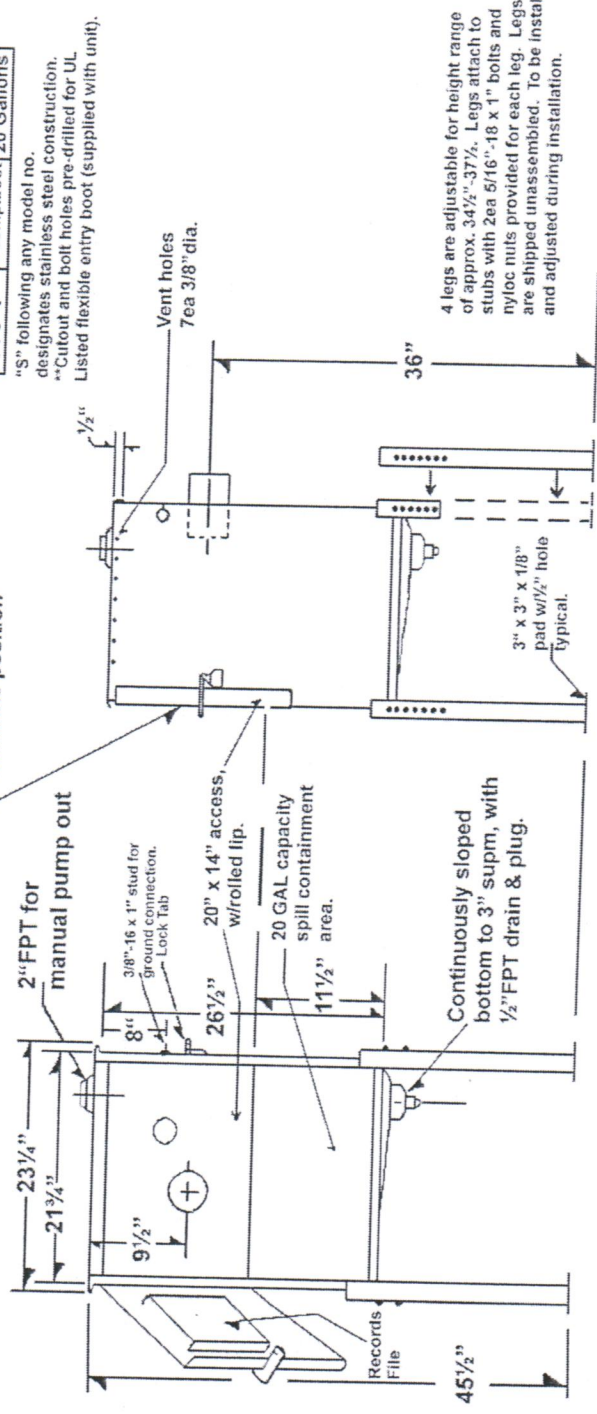
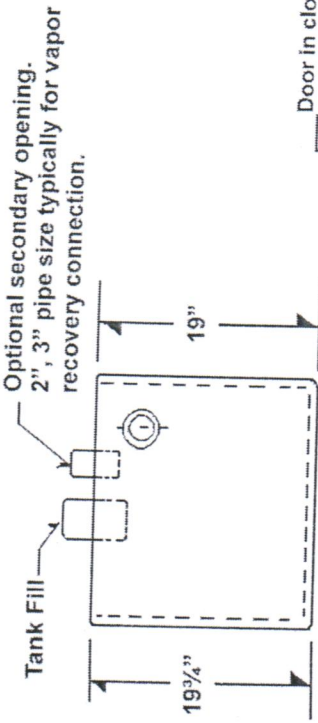

MODEL	FILL	CAPACITY
700-2	2" MPT	20 Gallons
700-3	3" MPT	20 Gallons
700-4	4" MPT	20 Gallons
750-2	2" FPT	20 Gallons
750-3	3" FPT	20 Gallons
750-4	4" FPT	20 Gallons
770-2**	2" comp. boot	20 Gallons
770-3**	3" comp. boot	20 Gallons
770-4**	4" comp. boot	20 Gallons

\*"S" following any model no. designates stainless steel construction.  
\*\*Cutoff and both holes pre-drilled for UL Listed flexible entry boot (supplied with unit).

**MATERIALS:**

- SPILL CONTAINMENT CABINET: 16GA STEEL MINIMUM (ALT "S"-16GA MINIMUM STAINLESS STEEL)
- LEGS AND STUBS: 1 1/2" X 1/8" STEEL ANGLE (ALT "S"-1 1/2" X 1 1/2" X 1/8" STAINLESS STEEL)
- FILL AND DRAIN PIPE FITTINGS: ALL STEEL, SCH 40 MIN (ALT "S" S/S, SCH 40 MIN)
- LOCK TABS: 3/16" STEEL WITH 1/2"DIA PADLOCK HOLE (ALT "S"-3/16" STAINLESS STEEL)
- COATING: POWDERCOAT ZINC RICH EPOXY INTERIOR AND EXTERIOR W/2<sup>ND</sup> EXT POLYESTER (ALT "S" BARE STAINLESS STEEL, NO COATING)

**CAUTION**

FLAMMABLE OR COMBUSTIBLE LIQUIDS/VAPORS MAY BE PRESENT. KEEP AWAY SPARKS, FLAME, IGNITION SOURCES. EXTINGUISH SMOKING MATERIALS. FOR USE WITH PROPERLY VENTED STORAGE VESSELS. KEEP DOOR CLOSED AND LOCKED WHEN NOT IN USE.

This drawing and design are proprietary to BAKER INDUSTRIES NORTHWEST, and may not be copied or duplicated in whole or in part without the written permission of BAKER INDUSTRIES NW.

**#700 SERIES GROUND LEVEL SPILL CONTAINMENT SINGLE COMPARTMENT MODELS WITH LEGS FOR BOLTING TO FOUNDATION**

**BAKER INDUSTRIES NORTHWEST**

12428 Highway 99 South, Unit 56  
Everett, Washington 98204-5502  
Tel:(425)212-3169 • FAX:(425)353-6788 • e-mail: [ben@bakerindnw.com](mailto:ben@bakerindnw.com)  
[www.bakerindustriesnorthwest.com](http://www.bakerindustriesnorthwest.com)

DRAWN	CHECKED	DATE
LRG	RBW	03-28-95
SLG	LRG	03-05-06

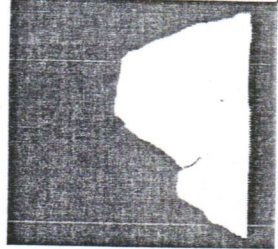

2554 2.7E  
15192 2.10E

# Underground Storage Tank Equipment

## 782 Drop Tubes

EBW drop tubes are available in two wall thicknesses. The thin wall (.035 thickness) models offer easy handling and installation. The heavy wall (.062 thickness) models offer more durability. The drop tube fits directly into the underground tank riser pipe in dual point vapor recovery and conventional non-vapor recovery fill systems. Fuel is efficiently delivered at a faster rate, and allows submerged filling, which generates less vapors and evaporation. The drop tubes are furnished with a straight cut bottom, which can be cut to length on the job site.

Note: For use with outside clamping drop elbows on adapter only. Do not use with inside expanding drop elbows.

2" size shipped six tubes per box.

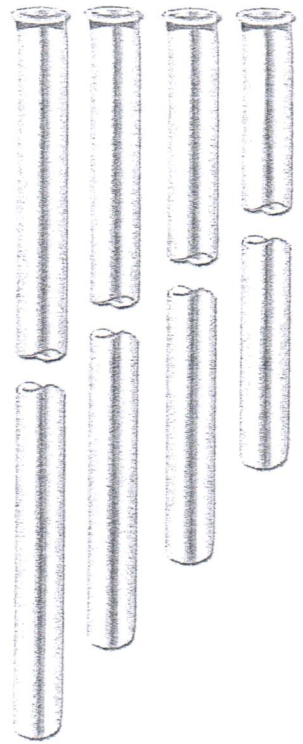

### Advantages

- Flared end with Buna-N gasket for positive seating.

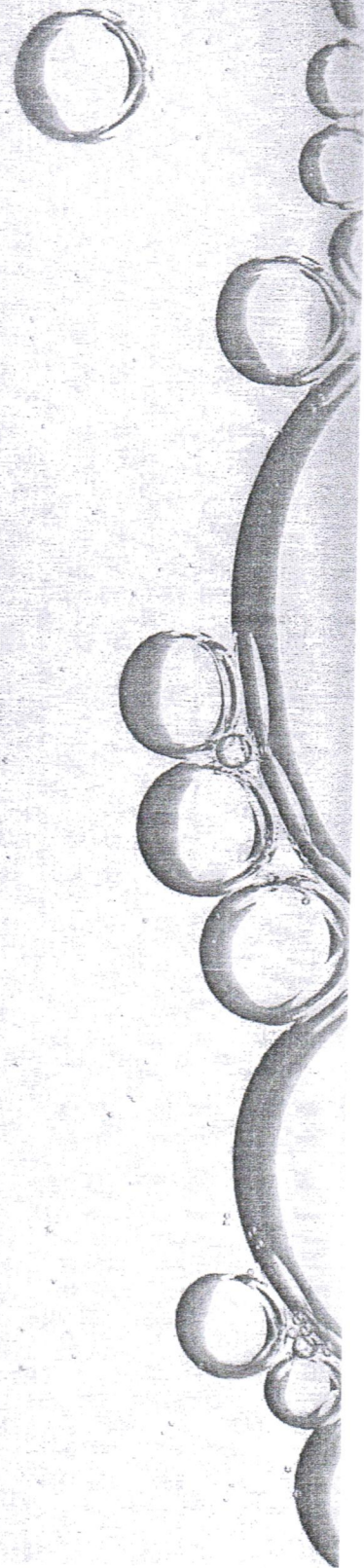

Service Station Hardware

Model	Tubes per Box	Size		Wall Thickness		OD		Weight		List
		In. x Ft.	mm x M	In.	mm	In.	mm	Lbs.	Kg	
782-202-12	6	2 x 12	51 x 3.66	0.42	10.67	1.88	48.00	45.00	20.41	
782-203-12	4	3 x 12	76 x 3.66	0.42	10.67	2.94	75.00	32.00	14.51	
782-204-10-2'	2	4 x 10	102 x 3.05	0.062	1.580	3.88	99.00	22.00	10.00	
782-204-12-2'	2	4 x 12	102 x 3.66	0.062	1.580	3.88	99.00	26.00	11.80	
782-204-15-2'	2	4 x 15	102 x 4.57	0.062	1.580	3.88	99.00	30.00	13.60	
782-204-30-2"	2	4 x 10	102 x 3.05	0.062	1.580	3.88	99.00	22.00	10.00	
782-204-32-2"	2	4 x 12	102 x 3.66	0.062	1.580	3.88	99.00	26.00	11.80	

\*CARB: EVR Phase I Certification VR-101 and VR-103.

\*\*Biofuel approved models (E85 and biodiesel). CARB: EVR Phase I Certification VR-101.

2554. 2.7 H

# Aboveground Storage Tank Equipment

15192 2.10 I

## Advantages

- Dome-shaped top design drains off moisture including rain, snow and ice.
- 30 mesh prevents dirt and debris from entering vent lines.

## Materials

- Body: aluminum.
- Lid: zinc plated steel.
- Seal: brass.

## 800 Tank Vents

EBW tank vents are designed to provide an open path for vapors from an underground or aboveground storage tank to the atmosphere.

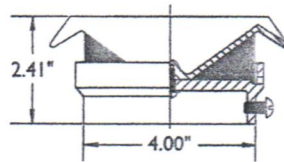
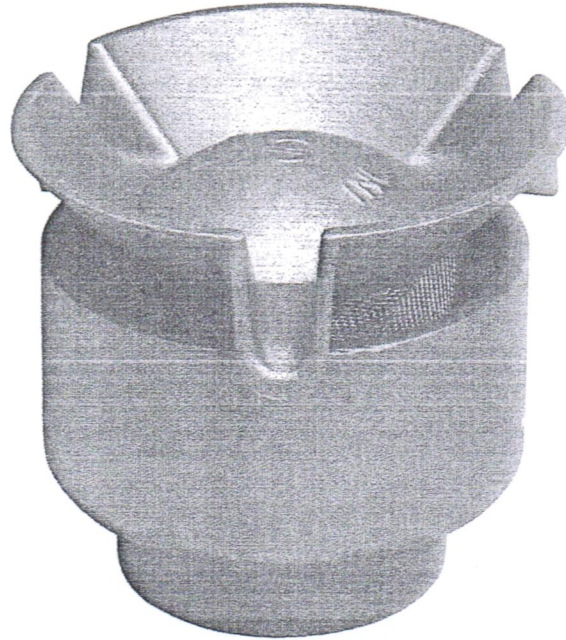

800-203-01

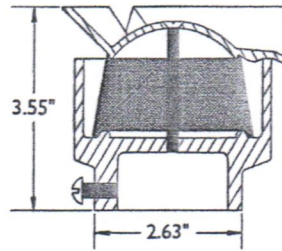

800-206-01

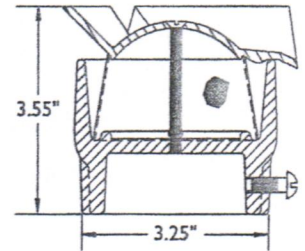

800-207-02

Model	Size		Weight		List
	In.	mm	Lbs.	Kg	
800-203-01	3.00	76.00	1.19	0.54	
800-206-01	1.50	38.00	1.00	0.45	
800-207-02	2.00	51.00	1.00	0.42	